

INSTRUCTIONS FOR USE

REPLACEMENT CONNECTOR & CAP KIT CC-1301

For Flex-Neck® Adult, Adolescent & Pediatric
Peritoneal Dialysis Catheters ONLY

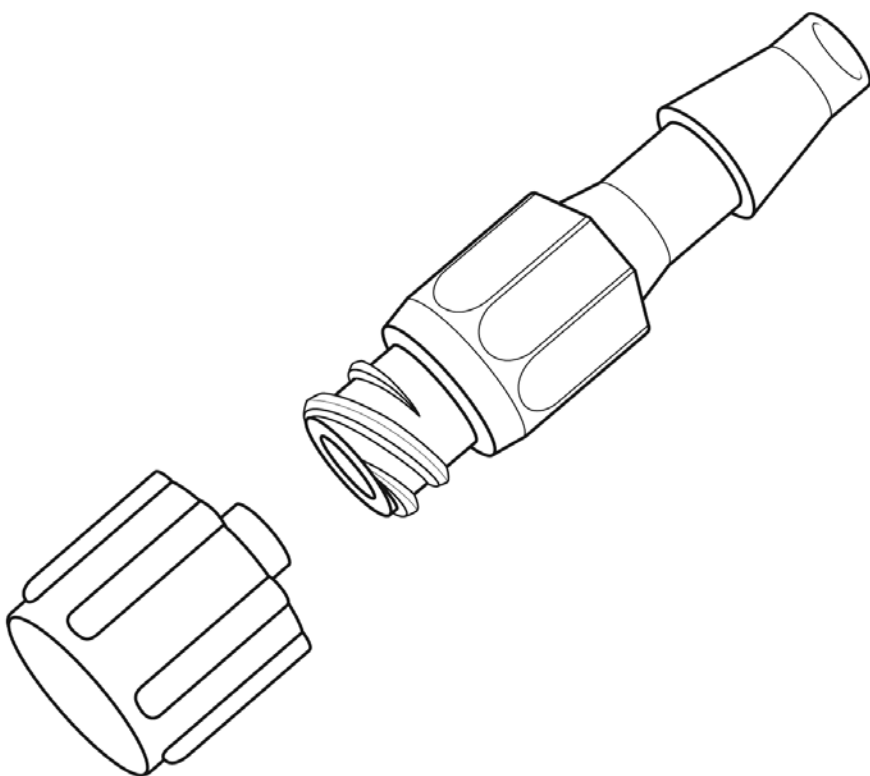

REPLACEMENT CONNECTOR & CAP KIT CC-1301

English

For Flex-Neck® Adult, Adolescent & Pediatric
Peritoneal Dialysis Catheters ONLY

PRODUCT DESCRIPTION

Replacement Connector and Cap Kit for Flex-Neck® Adult, Adolescent, and Pediatric Peritoneal Dialysis Catheter.

Each pouch contains one Connector and one Cap.

- Tapered Tip (A)
- Raised Shoulder Ridge (B)
- Finger Grip (C)
- Threaded Luer (D)
- Cap (E)

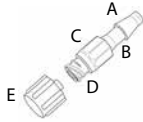

INDICATIONS FOR USE

The Replacement Connector and Cap are indicated ONLY for Flex-Neck Adult, Adolescent, and Pediatric Peritoneal Dialysis Catheters, to be used when a patient needs a replacement connector and cap.

CONTRAINDICATIONS FOR USE

Do NOT use with Flex-Neck Infant Peritoneal Dialysis Catheters. Do NOT use with other peritoneal dialysis catheter brands.

Rx Only; CAUTION: Federal (USA) law restricts this device to sale by or on the order of a physician.

PRECAUTIONS

- Read manufacturer's instructions prior to use.
- Contents are sterile (via ethylene oxide). Do not use if packaging is opened, damaged or broken.
- For single patient use only. Do not reuse, reprocess, or resterilize. Reuse, reprocessing, or resterilization may compromise the structural integrity of the device and/or lead to device failure, which in turn may result in patient injury, illness, or death. Reuse, reprocessing or resterilization may also create a risk of contamination of the device and/or cause patient infection or cross-infection, including, but not limited to, the transmission of infectious disease(s) from one patient to another. Contamination of the device may lead to injury, illness, or death of the patient.
- Do not use after expiration date.
- The medical techniques, procedures, and potential complications stated herein do NOT give full and/or complete coverage or descriptions. They are not a substitute for adequate training and sound medical judgment by a physician.
- Use an aseptic procedure to open the package and to remove the contents.

POTENTIAL COMPLICATIONS

- Infections (exit-site or tunnel)
- Peritonitis
- Sepsis
- Leakage (initial or latent)
- Catheter separation from the connector

CAUTIONS

- Catheter tubing can tear when subjected to repeated clamping, serrated-jaw forceps, excessive force, or rough tools.
- Do NOT use forceps with a serrated jaw.
- Do NOT use excessive force to lock the forceps closed.
- Use ONLY smooth-jawed forceps or equivalent.
- Do NOT clamp the catheter repeatedly in the same area.
- Do NOT clamp near the connector.

INSTRUCTIONS FOR USE

1. Create a sterile field for the procedure:
 - Prepare the patient's skin and catheter with a cleaning or disinfecting solution as needed per hospital protocol.
 - Drape the catheter exit-site area in an appropriate manner.
2. If clamping the catheter tubing with sterile hemostats or forceps, use only smooth-jawed forceps or equivalent. Do not use forceps with a serrated jaw as damage may occur. See cautions.
3. Prepare the existing Flex-Neck Catheter:
 - Cut catheter tubing just distal to the existing connector with sterile suture scissors, in a single, straight, perpendicular cut. Do not pull the connector off the catheter.
 - There must be at least 2.5 cm of catheter tubing remaining after trimming.
 - Verify that the cut is perpendicular to the tubing.
4. Wet the tapered tip (A) of the Replacement Connector with sterile saline or sterile water, and insert it into the catheter.
 - Do not use any other lubricant.
 - Do not use a twisting motion to force the catheter onto the Replacement Connector.
5. Push the connector into the catheter with a single forward motion.
6. Advance the catheter completely to the raised shoulder ridge of the Replacement Connector.



NOTE: The catheter tubing must completely pass over the tapered tip and to the raised shoulder ridge, but not beyond that onto the finger grip. See diagram above.

7. Pull carefully on the Replacement Connector and catheter to test the strength of the connection.
8. Attach either the Cap or a dialysis transfer set, to the threaded luer.



CATHETER CLEANING AND CARE

All Flex-Neck Peritoneal Dialysis Catheters are made of silicone. Exit-site cleaning agents that are compatible with silicone catheters therefore may be acceptable for use on Flex-Neck Peritoneal Dialysis Catheters. Such cleaning agents include:

- Electrolytically-produced sodium hypochlorite solutions (i.e., ExSept Plus®)
- Normal (sterile) saline

Cleaning agents that are non-irritating, non-toxic, anti-bacterial, and in liquid form are generally recommended.

The following cleaning agents are not compatible with silicone catheters, and are not recommended for use with Flex-Neck Peritoneal Dialysis catheters:

- Acetone or acetone-based products
- Povidone-iodine or iodine-based products

Merit Medical Systems, does not provide specific recommendations or protocols for exit-site care and cleaning, whether by the healthcare professional or by the patient. Appropriate exit-site and catheter care treatment protocols should be individualized for each patient, and established by the patient's physician(s), nurse(s), dialysis center(s), and/or other relevant dialysis healthcare professionals.

ExSept Plus is a registered trademark of Alcavis HDC, LLC or one of its affiliates.

Copyright © Merit Medical Systems, Inc. All rights reserved.



Manufacturer:

Merit Medical Systems, Inc.

1600 West Merit Parkway, South Jordan, Utah 84095 U.S.A.

1-801-253-1600 U.S.A. Customer Service 1-800-356-3748



Authorized Representative:

Merit Medical Ireland Ltd,

Parkmore Business Park West, Galway, Ireland

www.merit.com



ID 052213 402892001/A

